

(No Model.)

G. F. BALLOU.
SLIDE LATHE.

No. 359,381.

Patented Mar. 15, 1887.

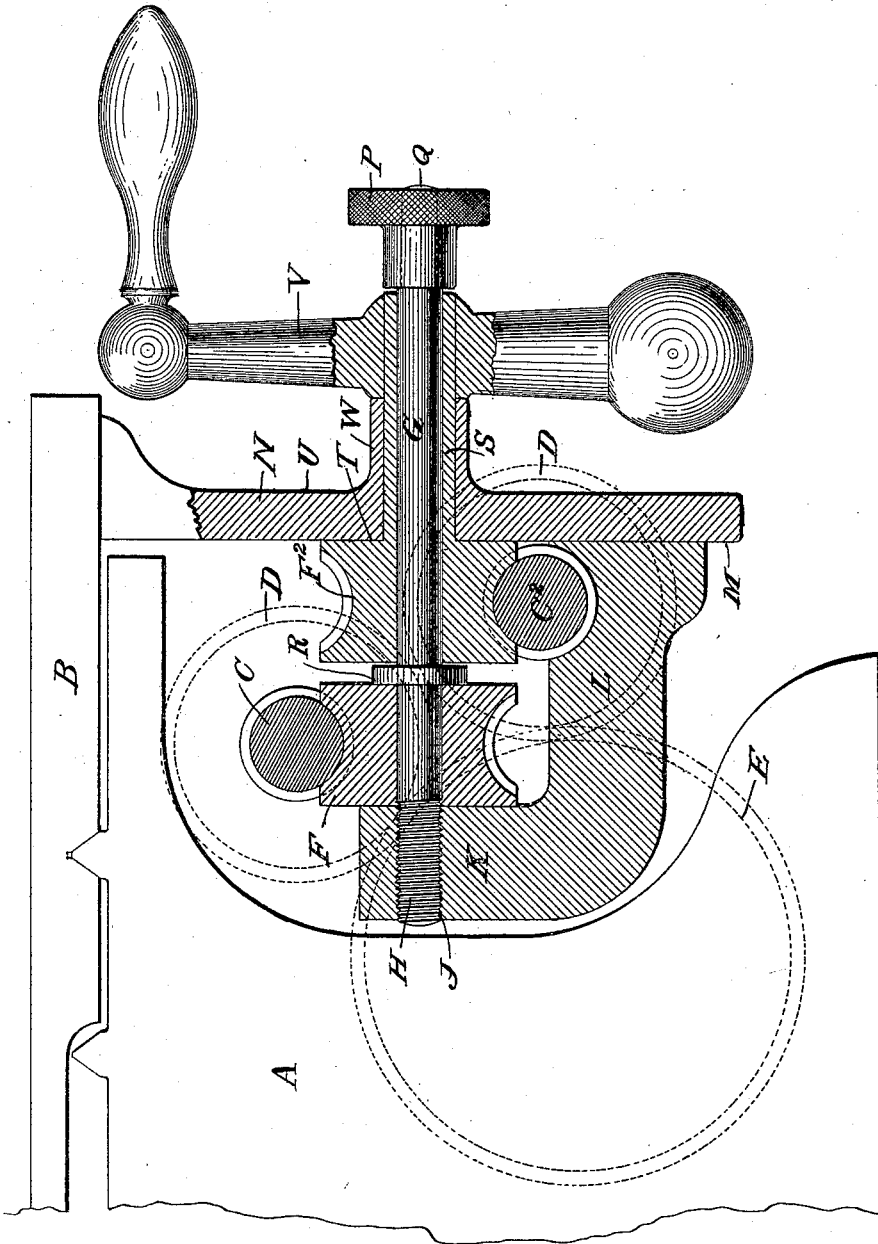

WITNESSES

Francis M. Brown,
Marion C. Brown.

INVENTOR

George F. Ballou
by his Attorneys
Brown Bros.

UNITED STATES PATENT OFFICE.

GEORGE F. BALLOU, OF WALTHAM, MASSACHUSETTS.

SLIDE-LATHE.

SPECIFICATION forming part of Letters Patent No. 359,381, dated March 15, 1887.

Application filed November 20, 1886. Serial No. 219,496. (No model.)

To all whom it may concern:

Be it known that I, GEORGE F. BALLOU, of Waltham, in the county of Middlesex and State of Massachusetts, have invented certain new and useful Improvements in Slide-Lathes, of which the following is a full, clear, and exact description.

This invention relates to that class of slide-lathes having two horizontal parallel geared leading-screws located on one and the same side of the lathe-bed or shears, a slide-carriage to be moved from the rotation of said leading-screws upon and lengthwise of the lathe-bed, and mechanism upon said carriage through which the carriage can be made to receive its movement from either of said leading-screws, as may be desired.

In substance the improvements of this invention consist of two horizontal parallel leading-screws located on one and the same side of the lathe-bed or shears and having threads preferably of opposite directions, and preferably geared to run in the same direction, a slide-carriage arranged upon the lathe-bed to be capable of moving lengthwise thereon in either direction, and mechanism which is located upon the slide-carriage and is constructed and arranged as to its separate parts and in relation to said leading-screws so that it can be adjusted and set to place the slide-carriage either into or out of operative connection with either leading-screw, and out of operative connection with both leading-screws, in the latter case with the leading-screws at rest, enabling the slide-carriage to be then moved along the lathe-bed in either direction through the rotation by hand of the part of said mechanism meshing with one of the said leading-screws, all substantially as hereinafter described.

In the drawing forming part of this specification, the figure is an end view of the lathe-bed or shears in part, and a transverse vertical section of the two leading-screws, and of portions of the slide-carriage, and of mechanism located on the carriage through which to place it into or out of operative connection with either or out of connection with both of said leading-screws.

As shown, the carriage is in operative connection with one of the leading-screws.

In the drawing, A is the lathe-bed or shears,

and B is the slide-carriage, and C C² the two horizontal parallel and upper and lower leading-screws at one and the same side of the lathe-bed, and all, except as hereinafter described, the same as ordinary or as well known, or otherwise, as may be suitable.

Each leading-screw C C² at one end is provided with a similar gear-wheel, D, which meshes with a common gear-wheel, E, which is located at the head-stock end of the lathe, and otherwise is arranged and driven all as well known in slide-lathes.

The rotation of the gear-wheel E rotates both leading-screws C C², and, as is plain, in the same direction. The threads of the leading-screws preferably run in opposite directions—that is to say, the thread of the one is right-handed and the thread of the other is left-handed; but they may both run in the same direction. The leading-screws are in different vertical and horizontal planes.

F F² are two similar worm gear-wheels, both carried by and loose upon a common horizontal stationary spindle, G, of the slide-carriage. This spindle G, at its inner end, H, is screw-threaded, and it is screwed into a screw-threaded socket, J, in the upper portion, K, of a bracket-arm, L, fixed to the rear or inner side, M, of the apron N of the slide-carriage, and at its outer end, Q, it is provided with a milled head, P, for convenience in turning it. The worm gear-wheel F is directly inside of the upper portion, K, of the bracket-arm L, and between it and a collar, R, surrounding the spindle, and meshes with the upper leading-screw, C. The worm gear-wheel F² is between said collar R and the rear or inner face or side, M, of the apron N of the slide-carriage, and it meshes with the lower leading-screw, C², and it also has a sleeve, S, which forms a shoulder, T, at the inner side of the apron, and extends loosely through the apron to and beyond its front or outer face, U, where it is provided with a winch or crank-handle, V.

The carriage-apron N is provided with a horizontal outward extension, W, to give increased length of bearing for the sleeve-extension R of the worm gear-wheel F².

By screwing the spindle G in one direction—that is, into the screw-threaded socket J therefor of its bracket-support L of the slide-carriage—its collar R will be brought to bear

against the inner worm gear-wheel, F, and thereby said gear can be firmly bound to the bracket and secured against rotation. Again, by screwing the spindle G in the other and opposite direction—that is, out of the screw-threaded socket J therefor of its bracket-support L of the slide-carriage—its collar R will be brought to bear against the outer worm gear-wheel, F², and thereby said gear-wheel can be firmly bound to the apron N of the slide-carriage and secured against rotation. With the inner worm gear-wheel, F, bound and secured, as described, the outer worm gear-wheel, F², is free for rotation about and upon the spindle, and vice versa, and by turning the spindle so that its collar R is free of contact or of a bearing upon either of said worm gear-wheels both are free for rotation upon and about their said common spindle.

Binding and securing either of the worm gear-wheels, as has been described, makes such worm gear-wheel a screw-nut to the leading-screw meshing with it, so that in the then rotation of such leading-screw the slide-carriage will be given a movement in accordance with the direction of the thread of that leading-screw—that is, to the right or left, as the case may be—along the lathe-bed or shears. With both worm gear-wheels unbound or released, as has been described, with the leading-screws then at rest, by turning the outer worm gear-wheel, F², by its handle V, the lower leading-screw, C², makes a gear or toothed rack, securing from its action, in co-operation with the rotating worm gear-wheel, the movement of the slide-carriage along the lathe-bed to the right or left, as the case may be, and according to the direction in which the handle may be turned.

With two leading-screws constructed and arranged and geared to rotate all as described, in combination with the mechanism of the slide-carriage having worm gear-wheels F F², meshing, respectively, with the leading screw-shafts and otherwise, all substantially as described, under the rotation of the leading-screws the slide-carriage can be given a movement along the length of the lathe-bed or shears in direction right or left, according as the said mechanism may be adjusted as described for operation from either the right or the left handed leading-screw of the two leading-screws, and the slide-carriage can be made capable of a movement along the lathe-bed in either direction—that is, to the right or left—by hand, both leading-screws at that time being at rest.

The threads of the leading-screws C C² may be of the same direction, either right or left handed, in lieu of opposite directions, as has been particularly described, without departing from the invention; and, again, the lead-

ing-screws may be geared directly together, in lieu of through an intermediate gear-wheel, E, as has been described. 65

Having thus described my invention, what I claim, and desire to secure by Letters Patent, is—

1. In a slide-lathe, in combination, two horizontal parallel leading-screws located on one and the same side of the lathe-bed, two worm gear-wheels, each meshing with a leading-screw and free to rotate on a common spindle which is carried by the slide-carriage and is constructed and arranged to secure either worm gear-wheel against and leave them both free for rotation, and means for rotating one of the worm gear-wheels by hand, substantially as described, for the purposes specified. 70 75

2. In a slide-lathe, in combination, two horizontal parallel leading-screws geared to rotate in the same direction and located on one and the same side of the lathe-bed, two worm gear-wheels, each meshing with a leading-screw and free to rotate on a common spindle which is carried by the slide-carriage and is constructed and arranged to secure either worm gear-wheel against and leave them both free for rotation, and means for rotating one of the worm gear-wheels by hand, substantially as described, for the purposes specified. 80 85 90

3. In a slide-lathe, in combination, two horizontal parallel leading-screws with threads of opposite directions and geared to rotate in the same direction and located on one and the same side of the lathe-bed, two worm gear-wheels, each meshing with a leading-screw and free to rotate on a common spindle which is carried by the slide-carriage and is constructed and arranged to secure either worm gear-wheel against and leave them both free for rotation, and means for rotating one of the worm gear-wheels by hand, substantially as described, for the purposes specified. 95 100

4. In a slide-lathe, in combination, two horizontal parallel leading-screws, C C², located on one and the same side of the lathe-bed, two worm gear-wheels, F F², each meshing with a leading-screw and free to rotate on a common spindle, G, having a collar, R, between said gears and carried by the slide-carriage, and constructed and arranged to secure either worm gear-wheel against and leave them both free for rotation, and sleeve-extension S of gear F², having a suitable handle for rotating it by hand, substantially as described, for the purposes specified. 105 110 115

In testimony whereof I have this day set my hand in the presence of two subscribing witnesses.

GEO. F. BALLOU.

Witnesses:

ALBERT W. BROWN,
FRANCES M. BROWN.